



Building Florence Together
Community Development Corporation

Annual Report

2024-2025

Year Two Two New Homes



MISSION

Building Florence Together Community Development Corporation exists to promote equality, economic vitality, and improve the quality of life for City of Florence residents. Our goal is to provide access to appropriate housing, revitalization of neighborhoods, and empower residents and small businesses through education and Workforce Development partnerships



VISION

The vision of the Building Florence Together Community Development Corporation is to ensure that all residents, neighborhoods, and small businesses are positioned for economic stability, revitalization, and growth so that the entire city will experience Full Life to Full Forward

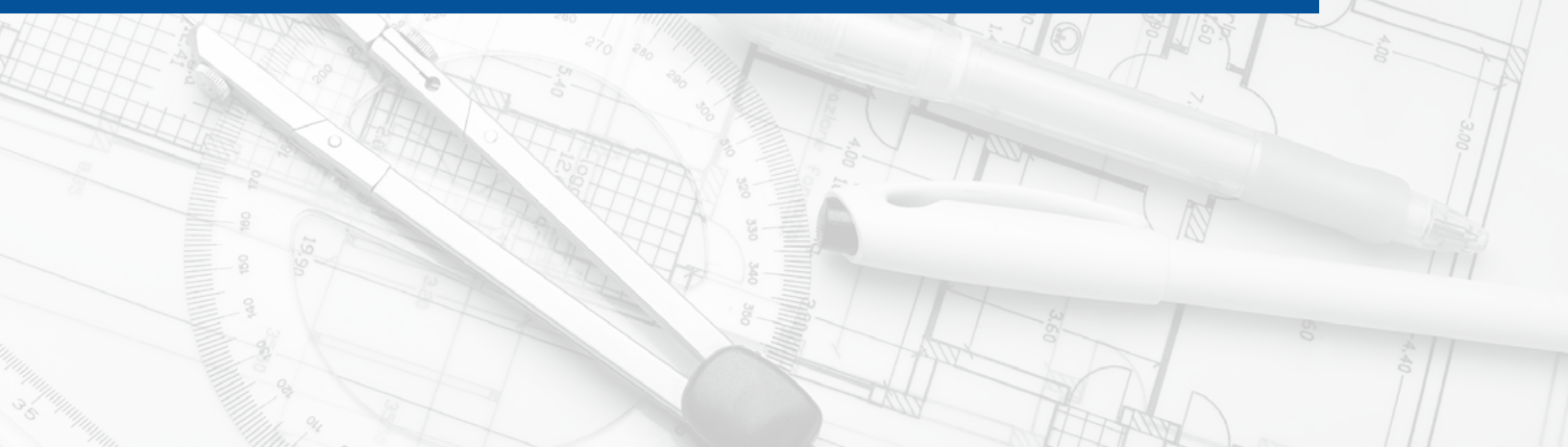

Board of **Directors**

Frank C. Swaggard

Board President

Employer: Wukela Law Firm

(Chris)topher Handley

Board Vice President

Employer: Helping Florence Flourish

Terrance J. Thomas

Board Treasurer

Employer: Retired

Tim Waters

Board Secretary

Employer: Community Market

Mr. Tyron Jones

Board Member

Employer: Florence-Darlington
Technical College

Jammie J. McDonald

Board Member

Employer: First Citizens Bank and
Trust Company

Les Echols

Board Member

Employer: Greater Florence
Chamber of Commerce

Suzanne La Rochelle

Board Member

Employer: Self-Employed

Devon Long

Board Member

Employer: Lee County School District



Letter from Executive Director, *Michelle L. Morgan*



A few minutes before I sat to pen this letter of reflection, I had the honor of signing a purchase contract with a prospective buyer for one of the homes in the Historical Pine District corridor that Building Florence Together Community Development Corporation (BFTCDC) just finished. It was truly a pleasure speaking with this client as she has worked at the Medical University of South Carolina (MUSC) for over 10 years and recently got custody of her two grandsons. She mentioned that renting has become unaffordable, and she was going to try to purchase a home after working to repair her credit since 2022.

This client is the “WHY” for me. Families like this fuel me to find opportunities to increase the economic viability of Florence residents. It is truly an honor to be able to provide quality affordable homeownership opportunities for deserving families in our community.

As I celebrated two years of being the Executive Director of Building Florence Together CDC, I am thankful for the accomplishments. This year we celebrated the following victories:

- Recipient a \$7500.00 Grant from the First Citizens Bank Foundation
- Obtained our SAMS UEI Number to Apply for Governmental Funding
- Achieved “Excellent” Rating on the 1st Formal Financial Audit by Websters and Rodgers LLP
- Conducted a beautiful Groundbreaking Ceremony to Begin Construction on 2 New Homes in the Historical Pine District
- Approved for a Commercial Line of Credit for \$500k from First Citizens Bank for Leverage and Future Scalability
- Received 11 Rental Units from Florence Affordable Housing Company/City of Florence
- Purchased Two Private Lots in the East Florence Area
- Awarded 3 Additional Lots from the City of Florence
- Constructed 2 New Homes in the Historical Pine Street Corridor

We would not be celebrating these successes if it wasn't for the wonderful partnership and the generous support from City of Florence and the amazing contributions of thought and time from our Board of Directors.

I also want to express appreciation for First Citizen's Bank for assisting us to leverage our existing assets with a \$500k Commercial Line of Credit and operations grant of \$7,500.00.

I am truly thankful for the opportunity to serve this great city.

We're just getting started. Let's Build Together!

Sincerely,

Michelle L. Morgan, MBA

Executive Director, Building Florence Together

Letter from Board President, *Frank “Clay” Swaggard*



On behalf of the Board of Directors of Building Florence Together Community Development Corporation (BFTCDC), I am writing to express our deep appreciation for the City’s ongoing partnership and to report on our accomplishments over the past year.

I also want to reaffirm our commitment to supporting the City’s revitalization priorities and to highlight the critical role our organization plays in supporting families within the community through property management, housing rehabilitation, and neighborhood development.

Over the past 12 months, BFTCDC has worked diligently to advance its mission: promoting equality, economic vitality, and an improved quality of life for Florence’s residents. I am most proud of the work that BFT has done in the housing rehabilitation, property management, and new construction spaces. For example:

- BFTCDC is currently building two (2) single-family homes at 557 E. Pine Street and 559 E. Pine Street.
- BFTCDC has initiated/or finalized the acquisition of lots at 322 S. Gaillard, 315 S. Gaillard, 421 S. Johns Street, and 607 E. Pine Street. All of which will lead to new construction projects in areas identified as ready for revitalization.
- BFTCDC is currently managing eleven (11) properties across the City of Florence and has invested in maintenance and repair for the benefit of families residing therein. Each unit that BFT manages is affordable and safe.

My goal for the coming year is for BFTCDC to continue to facilitate access to housing across Florence by responsibly leveraging the assets and resources entrusted to us. Our successes are only possible because of the partnership we maintain with the City of Florence. By prioritizing the removal of often vacant and deteriorated properties in our neighborhoods, we strengthen property values, decrease crime pressures, and increase demand in the surrounding area.

We are proud of what BFTCDC has accomplished this past year, but we recognize that many challenges remain. Florence’s future, especially for its most vulnerable neighborhoods and families, depends on cooperative effort.

The Board and I reaffirm our commitment to maintain an open and accountable relationship with the City Council, City staff, and the citizens we all serve. With your continued help, we believe the next year can yield even greater gains in neighborhood stability, resident opportunities, and progress.

Thank you for your time, your service, and your ongoing support of Building Florence Together.

Respectfully,
Frank “Clay” Swaggard
President, Building Florence Together Board of Directors

Financials

Statement of Assets, Liabilities & Net Assets-Modified Cash Basis

As of June 30, 2025 and 2024

ASSETS

CURRENT ASSETS	2025	2024
General Operating Checking Account	\$ 54,399.39	5170.92
Money Market Savings	515,960.61	204,027.77
Rental Account	14,552.74	0.00
Restricted Reserve Checking	5,500.00	5,500.00
Certificate of Deposit	506,136.77	400,000.00
Real Estate	2,221,368.40	81,861.00
TOTAL CURRENT ASSETS	\$ 3,317,917.91	696,379.69
TOTAL ASSETS	\$ 3,317,917.91	696,379.69

LIABILITIES AND NET ASSETS

CURRENT LIABILITIES	2025	2024
TOTAL CURRENT LIABILITIES	\$ 157,800.00	0.00
	157,800.00	0.00

LONG-TERM LIABILITIES

TOTAL LONG-TERM LIABILITIES

NET ASSETS	2025	2024
Net Assets with Donor Restrictions	\$ 5,500.00	5,500.00
Net Assets without Donor Restrictions	3,154,617.91	690,879.69
Closing of Net Assets	(2,469,738.22)	(296,050.50)
Change in Net Assets	2,469,738.22	296,050.50
TOTAL NET ASSETS	\$ 3,160,117.91	696,379.69
TOTAL LIABILITIES AND NET ASSETS	\$ 3,317,917.91	696,379.69

Groundbreaking Ceremony

Blessing of the Build

On March 12th, 2025, we broke ground for two brand new homes in the Historical Pine Street Corridor District. 557 and 559 E. Pine Street was vacant land and now stands two new quality affordable homes built by AllStar Homes SC. Guest Speakers included the Honorable Mayor Lethonia Barnes and City Manager Scotty Davis. The homes and ground were blessed by Reverend Mrs. Elma Galbreath who is a life-long resident of East Florence.



Groundbreaking Ceremony

Blessing of the Build (cont'd.)



Neighborhood Impact

The New Construction Begins!

Historical Pine Street Corridor - Housing Concept and Build

One of the goals of Building Florence Together Community Development Corporation (BFTCDC) is to build quality affordable homes for deserving families. Many of our clients are hard-working individuals who simply need an opportunity to obtain their goal of homeownership. BFTCDC works with these families to provide financial literacy education and down payment assistance to put homeownership within reach.

When BFTCDC considers a home design for our clients, we keep affordability, energy-efficiencies, storage, and most importantly a porch in mind. The porch symbolizes community, pride in homeownership and neighborhood stability. You will always see BFTCDC builds with our trademark porch.



Foundation



Framing



House Wrap & Windows



Final Construction

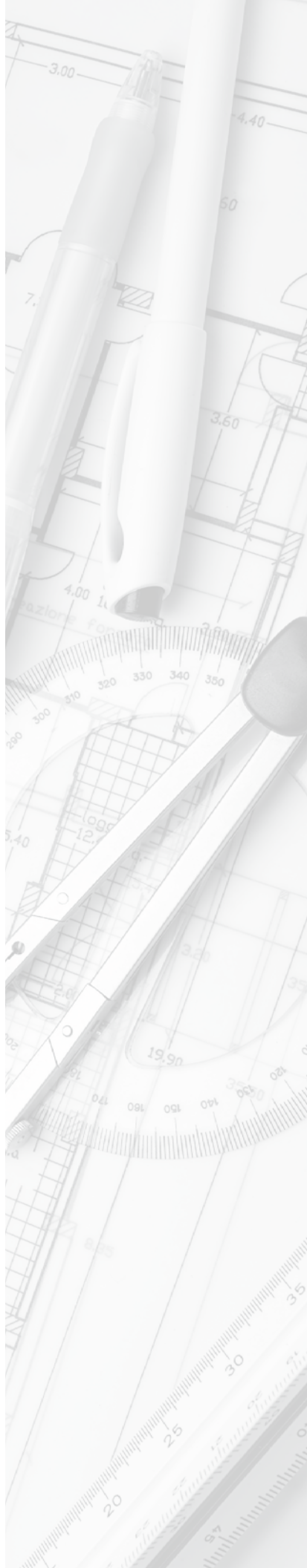

Final Construction



Builder Spotlight

All Star Homes SC LLC

**Mr. Darial Chapman,
President and CEO**

All Star Homes SC has been in business for over 17 years building executive, custom and affordable homes in South Carolina. All Star Homes was successful in obtaining the bid to build two homes for BFTCDC. When asked how his experience has been working with Building Florence Together Community Development Corporation he states, "It's been a pleasure working with BFT. The entire staff has been helpful throughout the process. I look forward to bidding on future projects with the organization."





843-665-3175



mmorgan@cityofflorence.com



<https://www.cityofflorence.com>



324 W. Evans Street
Florence, SC 29501